

Heavy Duty Cast Iron Slide Gates

Series HG560



72"x72" Heavy Duty Cast Iron Slide Gate

Applications

- Municipal Sewage Treatment Plants
- Municipal Water Works
- Power Plants
- Flood Control Projects
- Dams
- Industrial Water Control Projects
- Fish Hatcheries

Description

Cast iron slide gates are used to control the flow of fluid through openings under a face or seating head, and openings under a back or unseating head.

With seating or face pressure, fluid exerts a force on the front of the gate. The pressure of the water forces the gate slide against the frame. In the design of a structure where cast iron slide gates are used, place the gate so that it will be subjected to a higher seating head whenever possible. When this is done, a lighter gate can be used, and is usually more watertight.

Unseating or back pressure is encountered when the depth of fluid is greater on the back side of the gate. Under these conditions, the fluid force pushes the slide away from the frame and the total force must be resisted by the wedging devices and assembly bolts of the gate. Therefore, gates are designed for considerably less back pressure than they are for face pressure. The possibility of leakage increases with the fluid pushing the slide away from its seating surfaces.

Gate Openings

Three types of openings are available.

1. Square
2. Rectangular (Width x Height)
3. Round Flange

Most cast iron slide gates are used with square openings; however, many standard sizes of rectangular gates are available. It is standard practice throughout the gate industry to first designate the width of the rectangular gate opening, followed by its height. Openings are normally shown in inches. Gates with circular openings are manufactured by Hydro Gate with a round flange back for attaching to pipe flanges.

Pressure (Head) Ratings

Heads are measured from the horizontal centerline of the gate opening to the surface of the water. The majority of gate applications can be handled by Hydro Gate Series HG560, which has a minimum seating rating of 55 ft and 20 ft unseating. This series was developed using a finite element analysis of the Model 55-20 Heavy-Duty Sluice Gate, which qualified for use in nuclear power plant safety systems.

The Model 100-30 has a minimum seating head rating of 100 ft and a 30 ft unseating rating. The Model 100-30 has the same basic design as the Series HG560 and Model 55-20. There are some minor differences in the attaching detail of top and bottom wedges.

Any given size of gate in any model may have an actual safe design rating exceeding the nominal 55-20 or 100-30 rating., thus Hydro Gate reserves the right to furnish a gate that meets or exceeds the project operating requirements based on the gate's specific safe rating. Actual ratings can be obtained by calling your local sales representative or the Hydro Gate Engineering Department.

Many unique sizes and configurations of gate patterns in Series HG560 and 100-30 have been developed, and Hydro Gate reserves the right to furnish them as appropriate for special applications.

Gate Frame

The gate frame forms the shape of the opening (see Figure 1-1). Various types of frames have been available in years past. Hydro Gate has made the flange back frame its standard because it is the strongest and most universal of all of those that were used. The flange back frame has greater rigidity than other types of frames, which allows it to better withstand abnormal forces encountered during shipment, handling, and installation. Square and rectangular flange back frames can be installed with the minimal side and bottom clearances that normally would be needed for old-style flat back gates.

The frame is machined on its back face for attachment to a wall thimble. The frame also can be attached to a wall of the structure with anchor bolts, although this method usually takes longer than wall thimble mounting because the gate has to be carefully aligned and then grouted in place.

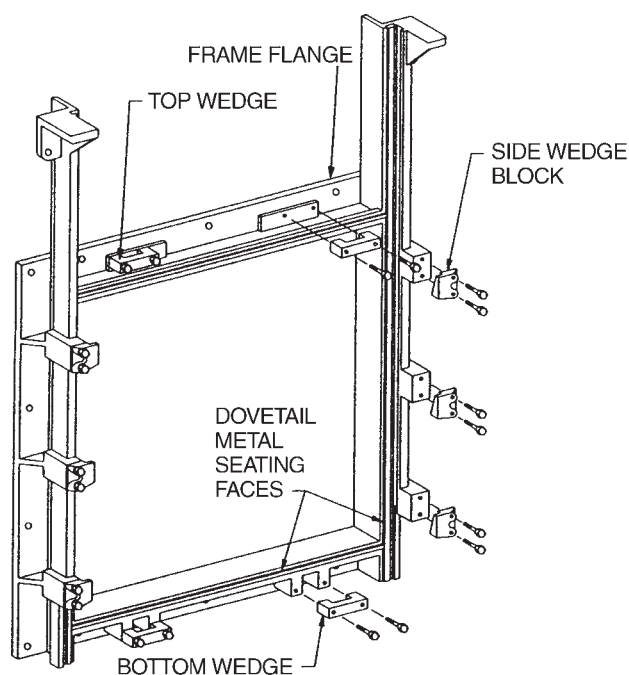

Figure 1-1
Hydro Gate Heavy-Duty Cast Iron Slide Gate Frame

Cast iron gate frames can be made self-contained by either extending the guides and furnishing a yoke to close the top of the frame, or by mounting a yoke with extended legs to the tops of standard-length guide bars. In either case, the tops of the guides are furnished with machine pads for mounting of a yoke.

Slide – General

The slide in any gate controls flow. Gates in the heavy-duty series have square or rectangular one-piece cast iron slides with vertical and horizontal ribs providing sufficient reinforcement to meet the design heads. (See Figure 1-2, page 4.) With the gate in the partially open position, the slide must have sufficient beam strength to transmit the total water pressure to the sides of the gate opening.

Wedge pads are cast as an integral part of the slide and each has a machined groove for the side wedge tongue. Guide tongues extend along each side of the slide for its full height and are fully machined. A heavy square or rectangular pocket is cast integrally with the slide to receive a stem block with a square or rectangular end for connecting the bottom end of the stem to the slide.

Slides for Rising or Non-Rising Stem Gates

Rising stem gates are recommended for all applications. The stem is anchored to the slide with a stem block mounted in a heavy block pocket cast integrally on the vertical centerline of the slide. The stem block transmits the stem thrust load into the slide and also resists the torque reaction of the stem nut. The slide and stem move up and down as a unit. The stem does not rotate and is locked to the stem block.

Non-rising stem gate slides have the heavy stem block pocket cast on the vertical centerline and are above the perimeter of the opening. This is done so that the stem does not extend significantly into the flow stream when the gate is open. A non-rising stem rotates but does not move up or down. As the stem rotates, the stem block becomes the thrust nut and is pulled or pushed along the stem and, in turn, pulls or pushes the slide up or down. The stem block resists rotation, because it has a square end fitting into a square pocket.

Non-rising stems should be used only in those locations where there is limited headroom or where the stem will interfere with some other part of the installation, such as a ceiling. The major disadvantage of the non-rising stem gate is that the threaded operating nut and stem are always in the exposed position in the gate well. Lubrication of the threaded portion is difficult, and lack of lubrication may cause excessive wear on the bronze operating nut. Operation problems of gates with non-rising stems increase with gate size. Sizes larger than 36 in. x 36 in. usually require a lift larger than a rising stem design.

In non-rising stem applications, there is a greater potential for excess wear on the threads, especially when they are not properly maintained. Non-rising stem gates are shown as standard for gate sizes up to 60 in. x 60 in. maximum. The use of non-rising stems is not recommended for large-size gates.

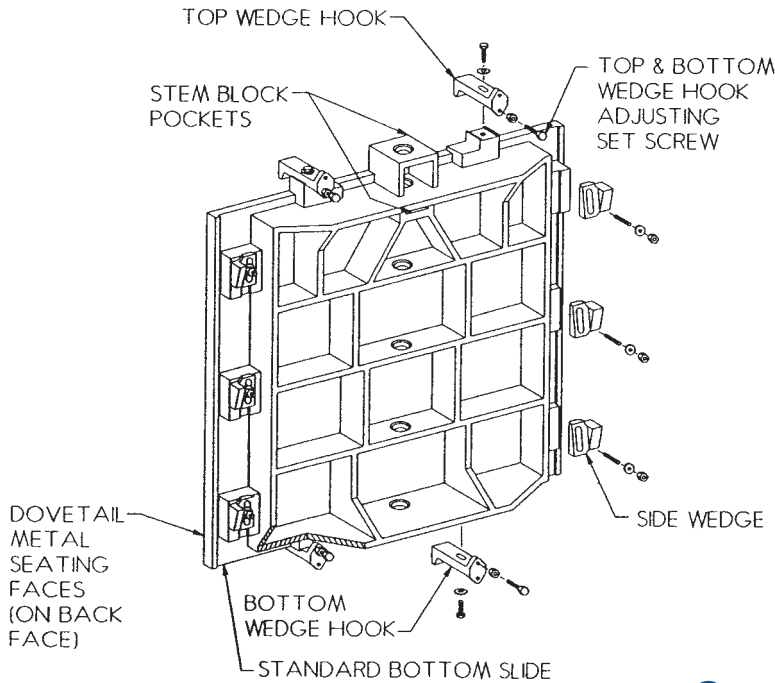

Figure 1-2
Hydro Gate Heavy-Duty Cast Iron Slide Gate Slide

Stem Block

Hydro Gate uses a block of metal, usually cast bronze, to connect the slide to the bottom end of the stem. The block is either a cube shape, a cylinder shape, or a cylinder shape with an integrally cast square flange on one end. The stem block is drilled and threaded for its full length. The stem block inserts into a pocket cast into the front of the gate slide. The lower end of the stem is threaded to match the block. For rising stem gates, the block is locked to the stem after it is screwed into place with a gib-type key. The stem block for a non-rising stem gate acts as a lift nut, and the stem is locked to the lift at the top of the stem. The threaded block for the non-rising stem gate raises or lowers on the stem as it turns and opens or closes the gate.

Slides for High Head Throttling Service

When cast iron slide gates are to be used under throttling conditions for seating heads greater than 65 ft, a 45° bevel should be utilized at the bottom edge of the slide. The bottom rib of the slide is tipped up at a 45° angle to the face of the gate to form this bevel. The flow through the partially opened gate is improved as the water travels along the bevel formed at the bottom of the gate slide, reducing down pull and minimizing vibration, turbulence, and cavitation.

Gates mounted on closed conduits or that are not open to the atmosphere should be fitted with an air-intake pipe of sufficient size to supply the air demand directly downstream from the gate. This will further reduce turbulence and improve flow through the partially open gate.

Standard or Flush-Bottom Closure

Most cast iron slide gates are furnished with standard bottom closures. The corrosion-resistant face across the bottom of the slide makes contact with the corresponding horizontal face across the bottom of the frame. The bottom edge of the slide has to travel beyond the invert of the gate to cause this type of closure to be made.

When gates are to be installed with the bottom of the opening at the same elevation as the invert of the structure, a flush-bottom closure-type gate is used. The bottom corrosion-resistant face is omitted from both the slide and frame. A rubber seating face is substituted along the bottom of the frame, and the top of this seal is flush with the gate invert. The gate slide now closes against the rubber seal in the invert.

Gate Frame Design

A gate frame forms the opening and constitutes the gate foundation on which all other parts are built. Frames are cast iron with a square, round, or rectangular configuration. The frames are of heavy, one-piece construction with integrally cast guides that support the slide. Grooves or guide slots are located in the frame, and the integrally cast guides are fully machined to receive the tongues on the sides of the slide. The machines guide slots are of sufficient length to support at least one-half the height of the slide when it is in the fully opened position. The top of each wedge pad is machined, drilled, and tapped for mounting of wedge blocks. Each wedge pad is supported by heavy cast iron gussets. The seating surface around the opening of the frame is machined to receive full-width dovetail facings of corrosion-resistant metal. Frame, guide groove, seating face, and wedge pads are machined on massive precision machines in a single setup to ensure precise fit and smooth operation of the gate.

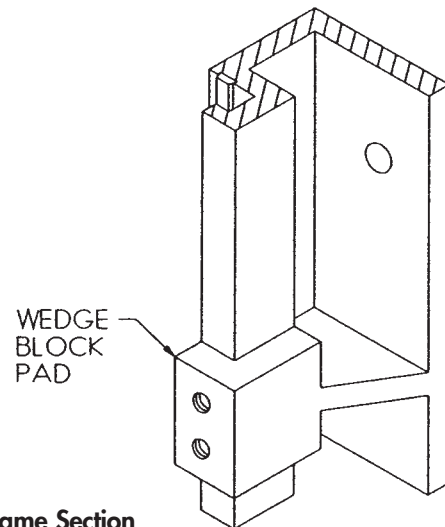

Figure 1-3
Flange-Back Frame Section

Flange Back

The flange-back frame is the strongest gate foundation available. (See Figure 1-3, page 4.) Because of the distribution of the material, the U-shaped section of the frame has a greater section modulus with minimal increase in weight. This extra strength reduces breakage and warping during handling, storage, and installation. The flange-back frame can be installed easily on a wall thimble. Attachment of this frame to a concrete wall or other flat surface using anchor bolts with double nuts (one nut in front, one in back of the flange) is also common practice. With either method, future removal of the gate is possible for maintenance or relocation.

The front flange is slightly narrower than the back flange all the way around its periphery. This allows direct access for placing nuts on studs or anchors to hold the gate in place on the thimble or wall. Minimum side and bottom clearances are needed for gate installation.

At each side wedge location, a heavy reinforcing rib or gusset is cast under the wedge pad between the front flange of the frame and the back flange. This reinforcing rib design is a result of computerized finite element analysis. With the use of this sophisticated computer analysis, the strength of the assembly is maximized with use of an optimum amount of metal. Additional rigidity eliminates deflection at the wedge point to improve water tightness under pressure.

Circular Openings

Square slides are used with all circular opening cast iron slide gates. The square slide provides for mounting of an adequate number of wedging devices and gives the slide the required beam strength when the gate is partly open.

The round opening is formed by casting webs of iron in the four corners of the frame. A section of metal extends back from this round opening to connect to a round flange.

THE ONLY TIME CIRCULAR OPENING CAST IRON SLIDE GATES SHOULD BE USED IS FOR ATTACHMENT TO EXISTING OR NEW PIPE FLANGES.

For all other installations requiring a round opening through the wall, a square flange round opening wall thimble is strongly recommended. By using this type of wall thimble, construction is simplified and a good mounting surface is provided for a square gate. Size and bottom clearances needed for installation are minimized, which permits the design of a narrower, less expensive structure.

Gate Slide Design

Hydro Gate heavy-duty cast iron slide gate slides are integrally cast with square or rectangular configurations. Cast iron slide gate slides utilize vertical and horizontal ribs to provide sufficient strength to meet the required design heads. Each horizontal rib on the slide combines with a section of the face plate to act as a T beam. With the slide under seating head, the

face plate section provides maximum strength to the T beam. Under unseating heads, the rib design is critical. Height and thickness, as well as spacing, provide the properties necessary to minimize the tensile stresses and deflection. For this reason, the slide is always rated for a seating head that is greater than the unseating head rating.



Side wedge and rib reinforcement detail

Hydro Gate has standardized on 55-ft seating and 20-ft unseating head ratings for our Series HG560 design. However, this is just a designated minimum rating and does not indicate the limits of a Hydro Gate heavy duty cast iron slide gate. Slides for higher heads are readily available and easily designed for specific applications. Please contact the Hydro Gate Engineering Department for details.

Heavy-duty cast iron slide gate slides can be designed with top and bottom wedges, top wedges and flush bottom, flush bottom and no top wedges, or no top and bottom wedges.

Optional Design Features

Hydro Gate can design and furnish special features for specific applications. A partial list of optional engineered features includes:

1. Bronze or stainless steel guide liners for frequent unseating head operation.
2. Inverted gate operation (downward opening) to act as a weir.

3. Piggyback mounting of pressure balancing valves or gate.
4. Non-standard mounting position such as inclined or horizontal movement.

Contact Hydro Gate Engineering Department for other special applications.

Full-Width Dovetail Seating Faces

Hydro Gate full-width, dovetail seating face is an exclusive Hydro Gate feature that eliminates all fasteners and ensures positive and accurate attachment of seating faces. (See Figure 1-4, below.)

A dovetail slot or groove is machined in the cast iron face of both the gate slide and frame. Full-width, corrosion-resistant metal facings are placed in the grooves and securely seated by pneumatically hammering a specific number of blows per inch of length. The design of the original chevron-shape raw seating face is such that the dovetail grooves are completely filled and the facings are locked and held in position for the full width and length. After seating, the faces are machined perfectly flat to ensure proper contact with each other when the gate is closed.

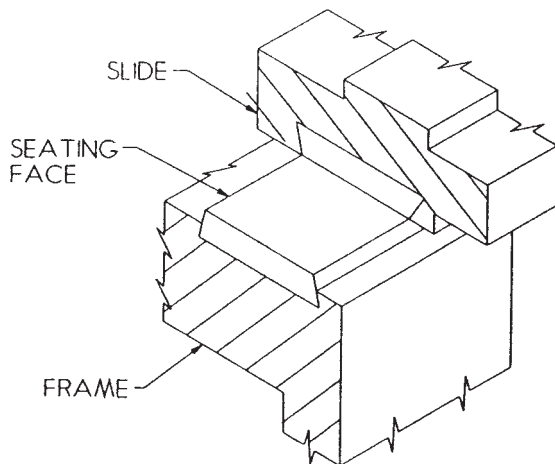

Figure 1-4
Dovetail Seating Face Detail

This method of mounting eliminates the possibility of leakage between the corrosion-resistant metal face and the casting because there are no voids or overhangs between the two, and the facing will not work loose during normal gate operation.

No fasteners are needed to hold seating faces in place, which avoids the possibility of fasteners allowing leakage or working loose and causing the gate to malfunction. With the full-width dovetail seating surface, the intersection of faces at the four corners is metal-to-metal and does not require fasteners, brazing, or other methods to seal them against leakage.

Painting

Painting of cast iron gates is primarily decorative. Cast iron by nature is corrosion resistant in water and waste-water. The high content of free carbon (graphite) in grey cast iron impedes progressive corrosion. Hydro Gate's standard paint for submerged gates and components is black coal tar epoxy paint. Hydro Gate can paint gate products according to customers' specifications within the limits of environmental regulations and paint manufacturer's recommendation.

Painting of gates with multiple coat systems or special colors adds significantly to production time and costs. The long-term life of the gate is not improved with "exotic" paint systems.

Standard paint on non-submerged components, such as lifts, is machinery enamel.

Materials

Frames and slides are grey cast iron for most applications in normal water. Frames and slides for seawater or brackish water, such as water used in pulp mills, should be made of nickel containing cast iron (Ni-Resist) to avoid graphitization and loss of strength under these harsh environments.

Naval bronze, silicon bronze, stainless steel, and Monel are available in full width dovetail sections. One of these metals is a suitable seating face material for virtually any proposed service or environment. The correct seating face material reduces corrosion at this vital location and improves gate operation.

For those installations where naval bronze does not offer the required protection against corrosion, Hydro Gate provides full-width dovetail seating faces of Type 304 or 316 stainless steel. These highly corrosion-resistant metal faces have approximately 18% chromium and 8% nickel. Stainless steel faces have a harder surface and resist wear. In those locations where low zinc bronze (less than 6% zinc) is needed to avoid possible dezincification, silicon bronze should be utilized. Unit pressures on the seating face are usually well below 2,000 psi, even under full wedge condition. Type 304 and 316 stainless steel can be used under these low unit pressures without the danger of galling.



Side wedge assembly

Side Wedge (Mounted on Slide)

Hydro Gate's side wedging device is completely adjustable and is firmly and easily locked in place. (See Detail 1-1, below, and Figure 1-6, page 8.) A groove is machined into each face of each wedge pad on the slide. A tongue on the back of the wedge fits into the groove and holds the wedge in alignment when it contacts the overhang portion of the wedge block. A slotted hole in the corrosion-resistant metal wedge allows for full adjustment. A unique design feature ensures positive locking of each side wedge in its correctly adjusted position. Opposing inclined surfaces are utilized to prevent slippage of the wedge and to eliminate the need for adjusting screws and lock nuts. The wedge mounting stud surface is machined at a taper in the opposite direction of the wedging face. The mounting stud is drilled and tapped into the slide at an angle which results in the stud being perpendicular to the opposing tapered surface on the wedge. As the gate is closed into the wedges, the side wedge position is fixed. The thicker section of metal resists being pushed under the nut and washer on the stud.

Wedging Devices

Wedging devices are used to force seating surfaces together when the gate is closed. Pads for mounting wedges and wedge blocks are cast as integral parts of the slide and frame. These pads are machined and drilled as required to receive wedging devices. All Hydro Gate heavy-duty gates are provided with side wedging devices in sufficient number to force the seating faces together when the gate is fully closed. For heavy-duty cast iron slide gates 24 in. and wider, top and bottom wedging devices are added when unseating heads are encountered.

Side wedges and wedge blocks can be individually removed and replaced if damage should occur after the gate is in operation.

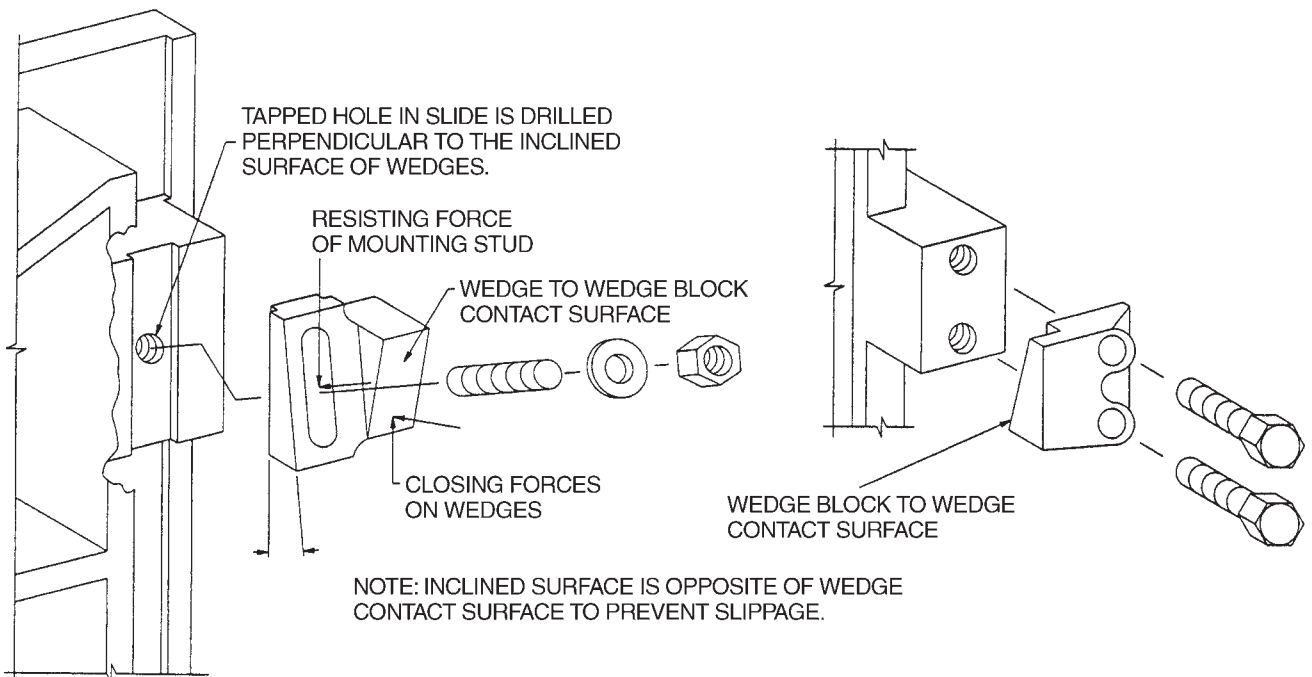

Detail 1-1

Series HG560 Heavy-Duty Cast Iron Slide Gate Slide Wedge and Side Wedge Block Details

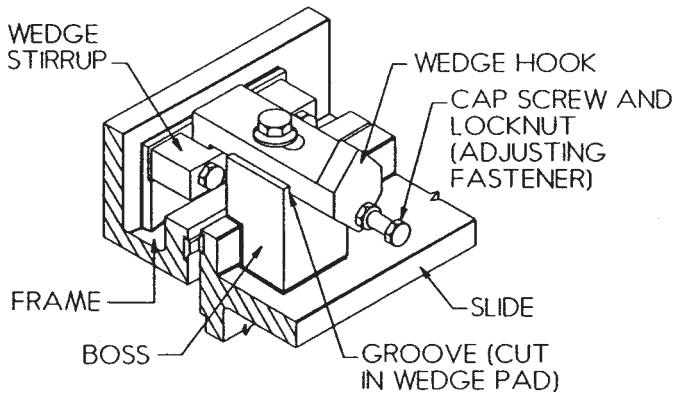

Figure 1-5
Top Wedging Device

Wedging action is between the projection of the wedge and a stirrup securely attached to the back flange of the gate by two cap screws.

The adjustable portion of the wedge is held in place by a groove cut in the top wedge pad which prevents turning of the wedge hook by an outside force.

Adjustment is by a separate fastener bearing against the boss on the slide (see Figure 1-5).

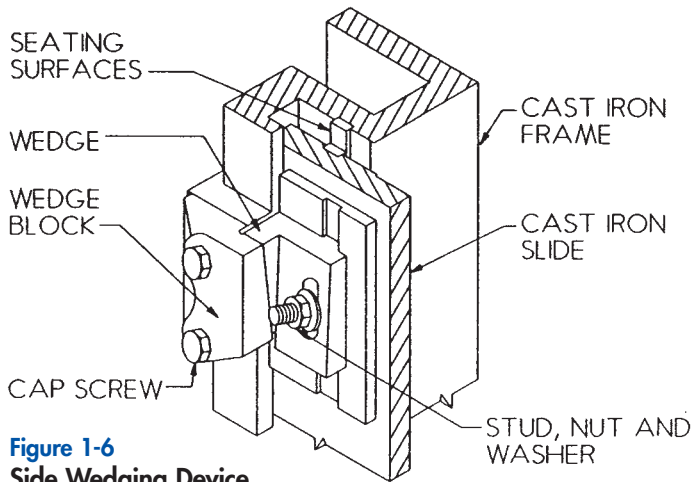

Figure 1-6
Side Wedging Device

A tongue on the back of the wedge fits into a machined groove on the slide and holds the wedge in alignment.

The stud holding the wedge to the slide is at an angle of less than 90° to the machined groove. When the nut on the stud is tightened, the wedge is firmly locked in position. Each wedge block is individually mounted on its pad on the gate frame with two fasteners (see Figure 1-6).

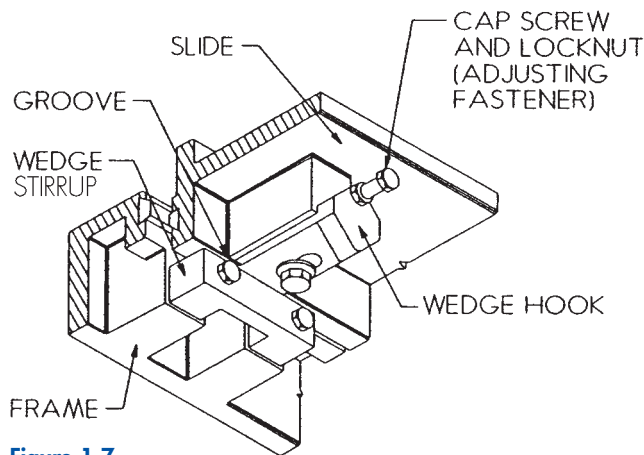

Figure 1-7
Bottom Wedging Device

Wedging action occurs when the projection on the bottom wedge hook engages the tapered surface inside the wedge stirrup, which is securely mounted to the back flange of the gate frame by two cap screws.

A full-width groove is cut in the pad on the slide to hold the wedge hook in alignment. As with the top wedge, the wedge hook cannot turn when the gate is in the partially open position. Positive adjustment is accomplished by use of a cap screw and locknut (see Figure 1-7).

Wedge Block (Mounted on Frame)

Hydro Gate wedge blocks are attached to a wedge pad on the gate frame with two oversized fasteners. These cap screws are sized to resist the wedging thrust loads. Low clearances on cap screw holes and high clamp forces in the cap screws resist any tendency of the wedge block to rotate. (See Detail 1-1, page 7, and Figure 1-6, page 8.)

The wedge block is designed with generous safety factors. The wedge blocks are easily replaceable and interchangeable during refurbishment and do not require the entire replacement of the frame if the frame is in good condition.

Top and Bottom Wedges

Top and bottom wedging devices are used when gates are subjected to unseating heads. The purpose of these wedging devices is to minimize deflection of the slide caused by pressure from the unseating head when the gate is in the fully closed position. The top and bottom wedges pull the seating faces together so water-tightness is improved. After the gate has been opened a fraction of an inch, these top and bottom wedges are no longer in contact with their mating surfaces and do not add to the strength of the slide.

Design of Hydro Gate top and bottom wedging devices positively prevents rotation of wedges at all times by one of the following methods:

- a) Series HG-560: Top and bottom wedges (hooks) are mounted in a machined slot on the side to keep them aligned. These wedges are mounted with a large corrosion-resistant cap screw and adjustment is maintained with an adjusting screw and jam nut. The adjusting screw bears against the slide casting to positively prevent rotation at all times.
- b) Model 100-30: Top and bottom wedges (hooks) are mounted on a machined pad on the slide with two corrosion-resistant cap screws. The adjustment is maintained as described above with a set screw bearing against the slide casting.

Hydro Gate's top and bottom wedging devices are adjustable. With the gate in a fully closed position and water on its back side, the adjusting screw can be tightened to pull the seating faces together. The design of the mounting pad and wedge hook prevent the adjusting screw from bearing against the mounting cap screw. This eliminates shear forces in the cap screw.



Top wedge assembly



Bottom wedge assembly

Flush Bottom Closures

- Provides unimpeded flow not subject to damage from flowing debris
- Fully supported on three sides
- Replaceable uniform section throughout length
- Minimizes damage caused by sunlight and wet and dry cycles

Flush-Bottom Closure Design

For normal standard bottom configuration, it is necessary for the slide to project below the bottom of the gate opening. In many installations, it is desirable to eliminate the recess in the floor needed for standard gate closure. A recess in the floor of a continuous structure tends to collect foreign material such as gravel, debris, and stagnant water. These foreign materials not only interfere with the flow, but also may prevent closing of the gate.

The Hydro Gate flush-bottom seal provides a flat plane across the bottom of the gate opening, with no part of the seal projecting into the opening to obstruct the flow. The seal is mounted on a stainless steel angle at the bottom of the frame and is held in place with a stainless steel retainer bar. The seal extends beyond the sides of the slide providing continuous contact across the bottom of the gate. This arrangement eliminates gaps and leakage at the sides of the gate opening as can be the case with flush-bottom seals mounted on the gate slide.

The rectangular rubber bulb seal is firmly supported on three sides. With only the top sealing surface exposed, damage from floating objects, wet/dry conditions, or sunlight is held to a minimum. Abrasion resistant rubber, along with a frame-mounted location, eliminates seat replacement problems. Slide mounted seals can be subject to these damaging problems. The knife edge across the bottom of the slide is rounded to prevent damage to the seal when the gate is closed. As the gate begins to seat, the seal conforms to the projection on the slide. When the gate is closed tightly, the seal is confirmed and reacts against the thrust of the slide to make a watertight seal across the bottom opening.

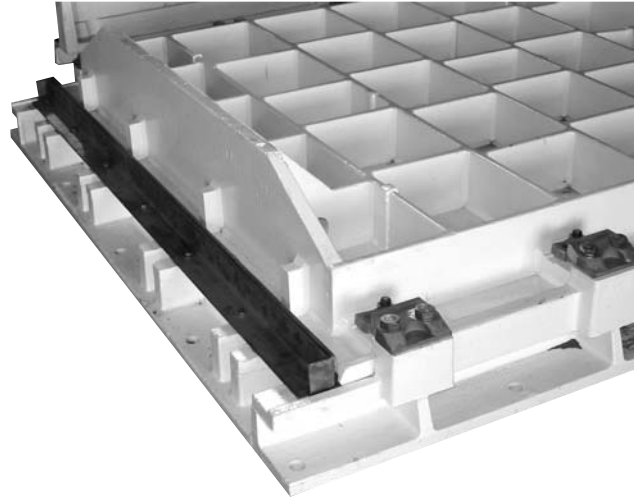

Flush bottom seal assembly

With only one surface of the rubber seal exposed, Hydro Gate flush-bottom seals are equally suited for operating heads in either direction. The flush-bottom seal takes the place of bottom wedges for unseating heads. With the gate slide in the fully closed position, the wide rubber seating face of the Hydro Gate flush-bottom seal makes firm contact with the machined sealing edge on the gate slide, regardless of the deflection of the slide under seating heads.

Following are typical installation type drawings that can be used for illustrative purposes in contact drawings or for brief submittals. Different options are available and applicable options wanted should be checked. For example, the gate should be either anchor bolt or wall thimble mounted. If mounted on a wall thimble, the type and overall length should be indicated.

Lifts are shown mounted on concrete or wall brackets. Please refer to the Lift and Lift Accessories brochure for details.

The dimension from centerline of gate to top of concrete should be indicated. This is the "H" dimension.

Installation Clearances for Series HG-560 Flush Bottom Gates

Gate Height (In.)	Recess Dimensions (In.)	
	Recess Height (B)	Recess Depth (C)
6 - 24	6	16
30 - 54	8	20
60 - 96	9	29
108 - 120	10	29

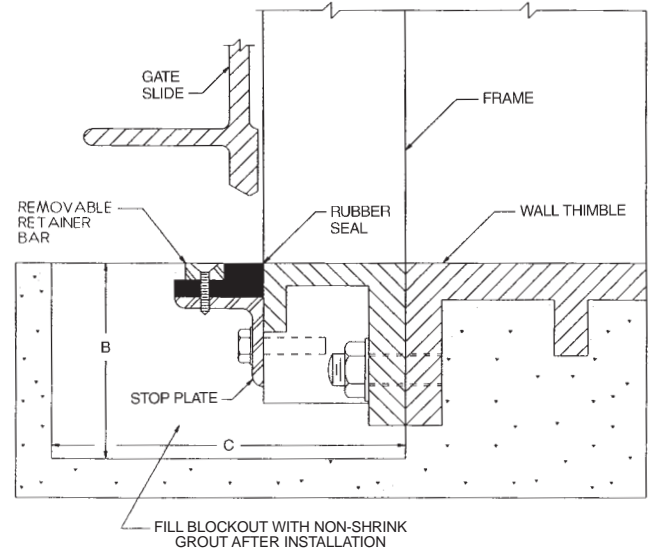
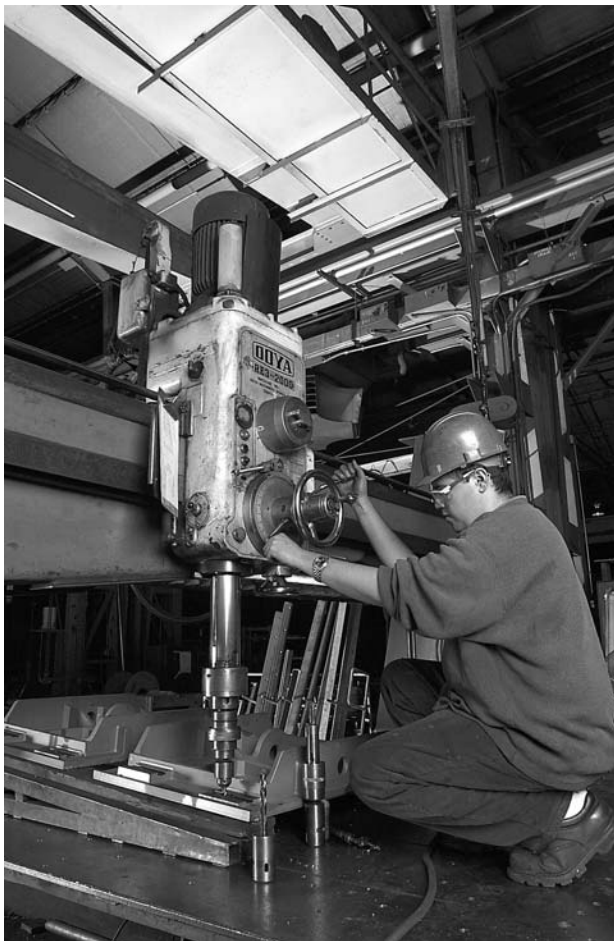
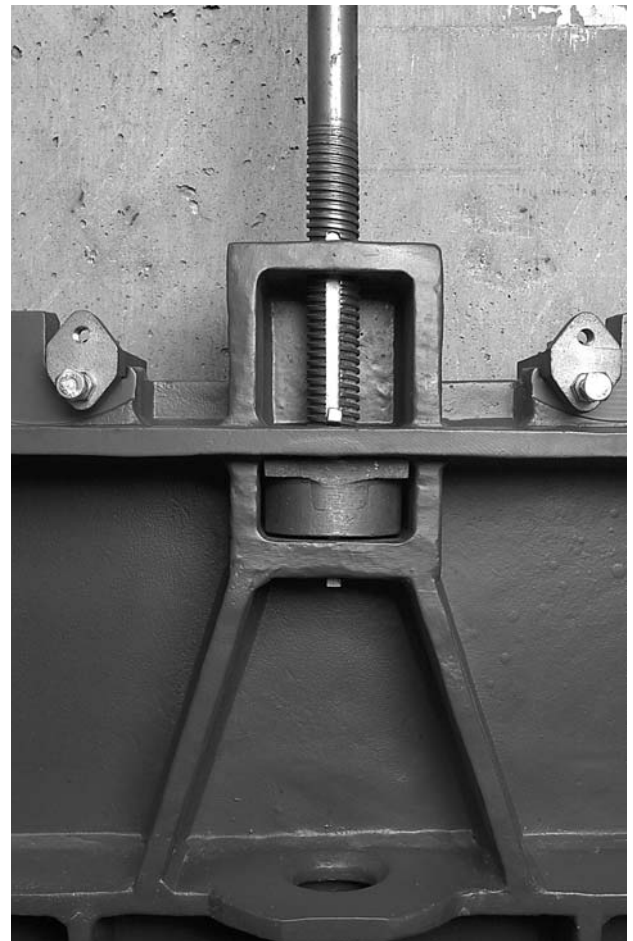

Figure 1-8
Heavy-Duty Cast Iron Slide Gate Flush-Bottom Detail



Drilling slide for wedges.



Stem block inserted into stem block pocket with threaded and keyed connection to stem.

Drawings and Dimensional Data

Select Options

- | | | | | |
|--|--|--|---|---|
| <input type="checkbox"/> Rising Stems | <input type="checkbox"/> Standard Bottom | <input type="checkbox"/> Top Wedges | <input type="checkbox"/> Wall Thimble Mount | |
| <input type="checkbox"/> Non-Rising Stem | <input type="checkbox"/> Flush Bottom | <input type="checkbox"/> Bottom Wedges | <input type="checkbox"/> Anchor Bolt Mount | |
| Wall Thimble Length (in inches) _____ | | | | |
| Wall Thimble Type: | <input type="checkbox"/> F | <input type="checkbox"/> E | <input type="checkbox"/> Mechanical Joint | <input type="checkbox"/> Lift Mounted on Concrete |
| Wall Thimble Opening: | <input type="checkbox"/> Round | <input type="checkbox"/> Rectangular | <input type="checkbox"/> Lift Mounted on Wall Bracket | |

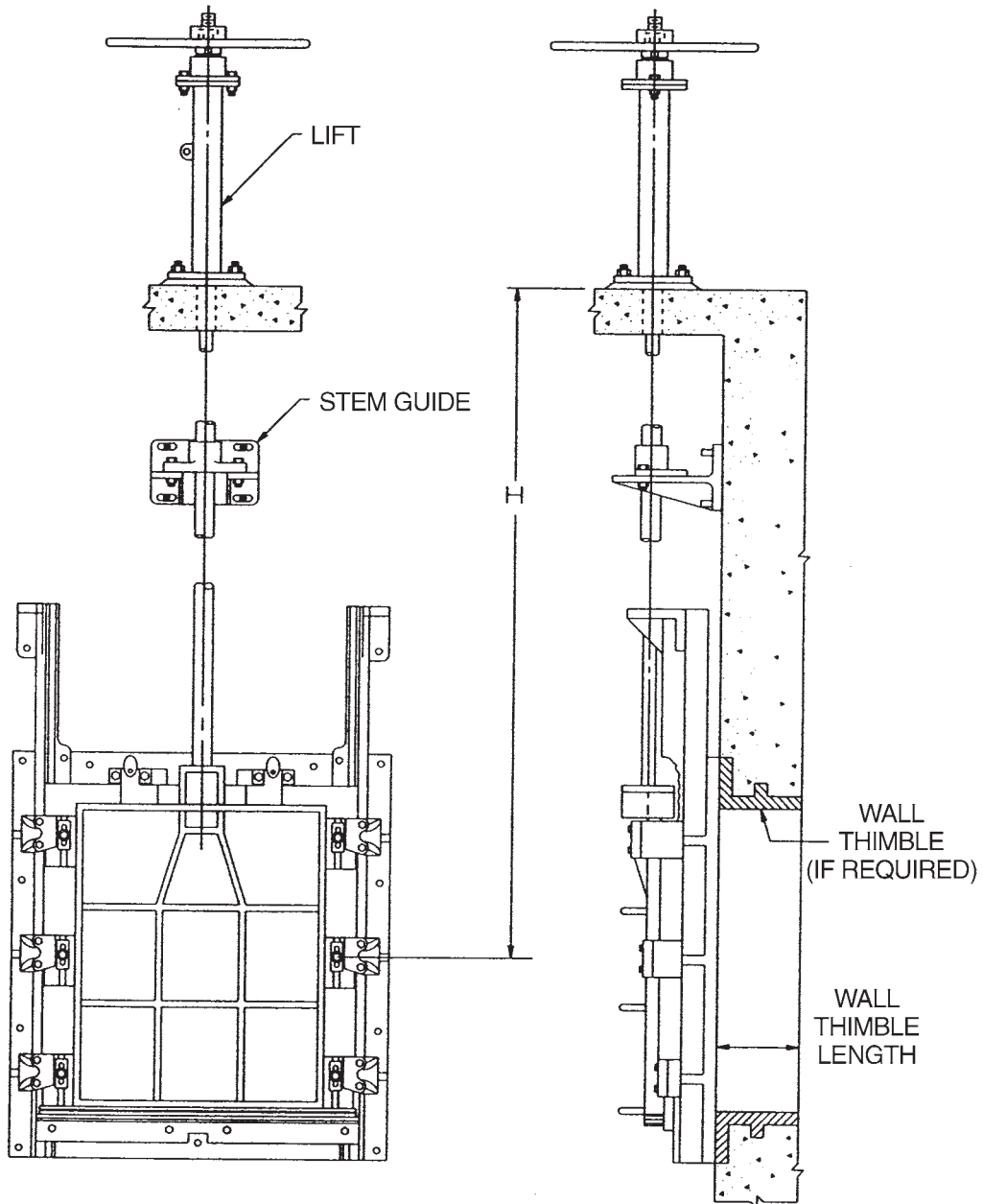

Figure 1-9
Handwheel Pedestal Lift – Heavy-Duty Cast Iron Slide Gate (Series HG-560)

Select Options

- | | | | | |
|--|--|--|---|---|
| <input type="checkbox"/> Rising Stems | <input type="checkbox"/> Standard Bottom | <input type="checkbox"/> Top Wedges | <input type="checkbox"/> Wall Thimble Mount | |
| <input type="checkbox"/> Non-Rising Stem | <input type="checkbox"/> Flush Bottom | <input type="checkbox"/> Bottom Wedges | <input type="checkbox"/> Anchor Bolt Mount | |
| Wall Thimble Length (in inches) _____ | | | | |
| Wall Thimble Type: | <input type="checkbox"/> F | <input type="checkbox"/> E | <input type="checkbox"/> Mechanical Joint | <input type="checkbox"/> Lift Mounted on Concrete |
| Wall Thimble Opening: | <input type="checkbox"/> Round | <input type="checkbox"/> Rectangular | <input type="checkbox"/> Lift Mounted on Wall Bracket | |

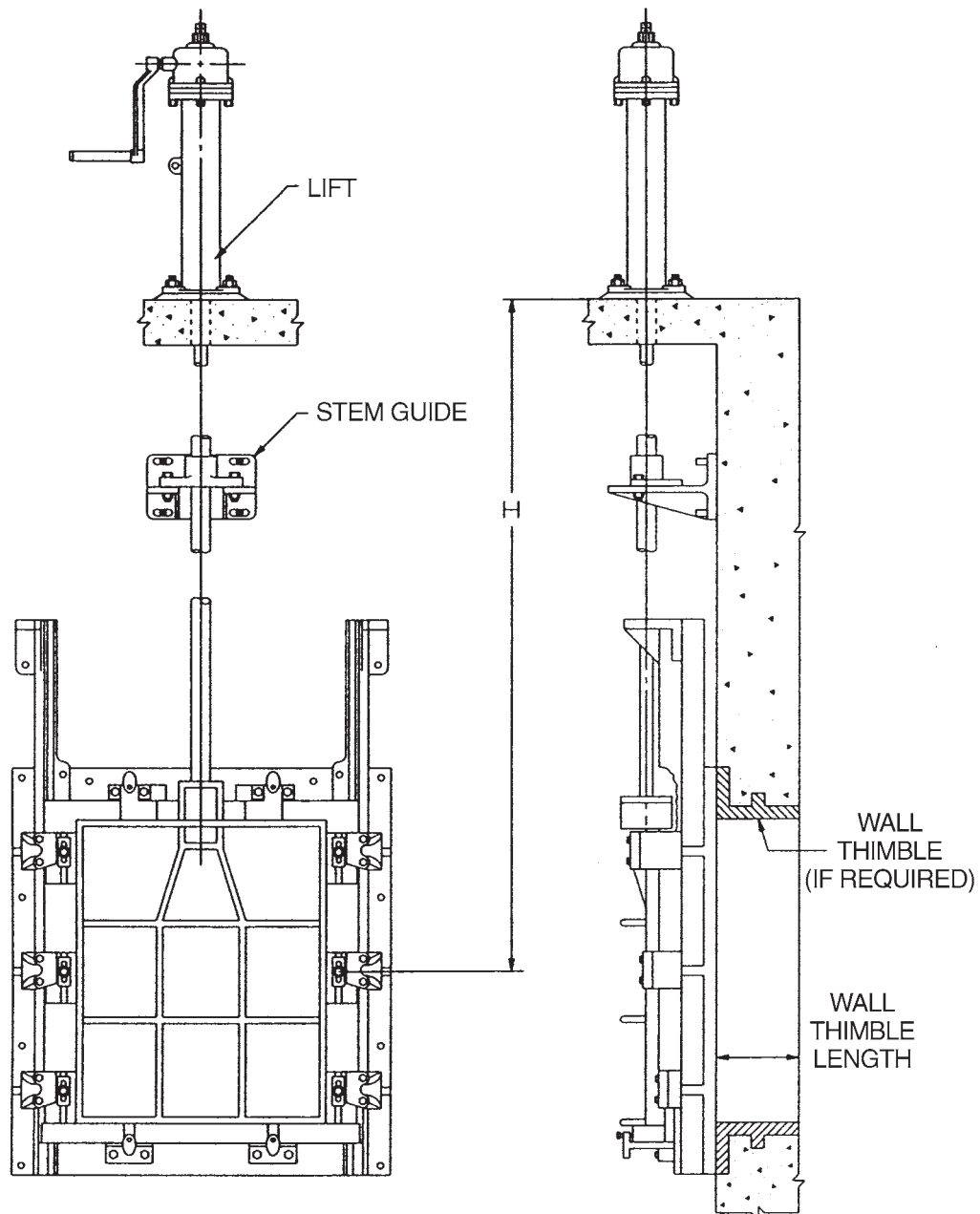

Figure 1-10
Enclosed Geared Pedestal Lift – Heavy Duty Cast Iron Slide Gate (Series HG-560)

Select Options

- | | | | | |
|--|--|--|---|---|
| <input type="checkbox"/> Rising Stems | <input type="checkbox"/> Standard Bottom | <input type="checkbox"/> Top Wedges | <input type="checkbox"/> Wall Thimble Mount | |
| <input type="checkbox"/> Non-Rising Stem | <input type="checkbox"/> Flush Bottom | <input type="checkbox"/> Bottom Wedges | <input type="checkbox"/> Anchor Bolt Mount | |
| Wall Thimble Length (in inches) _____ | | | | |
| Wall Thimble Type: | <input type="checkbox"/> F | <input type="checkbox"/> E | <input type="checkbox"/> Mechanical Joint | <input type="checkbox"/> Lift Mounted on Concrete |
| Wall Thimble Opening: | <input type="checkbox"/> Round | <input type="checkbox"/> Rectangular | <input type="checkbox"/> Lift Mounted on Wall Bracket | |

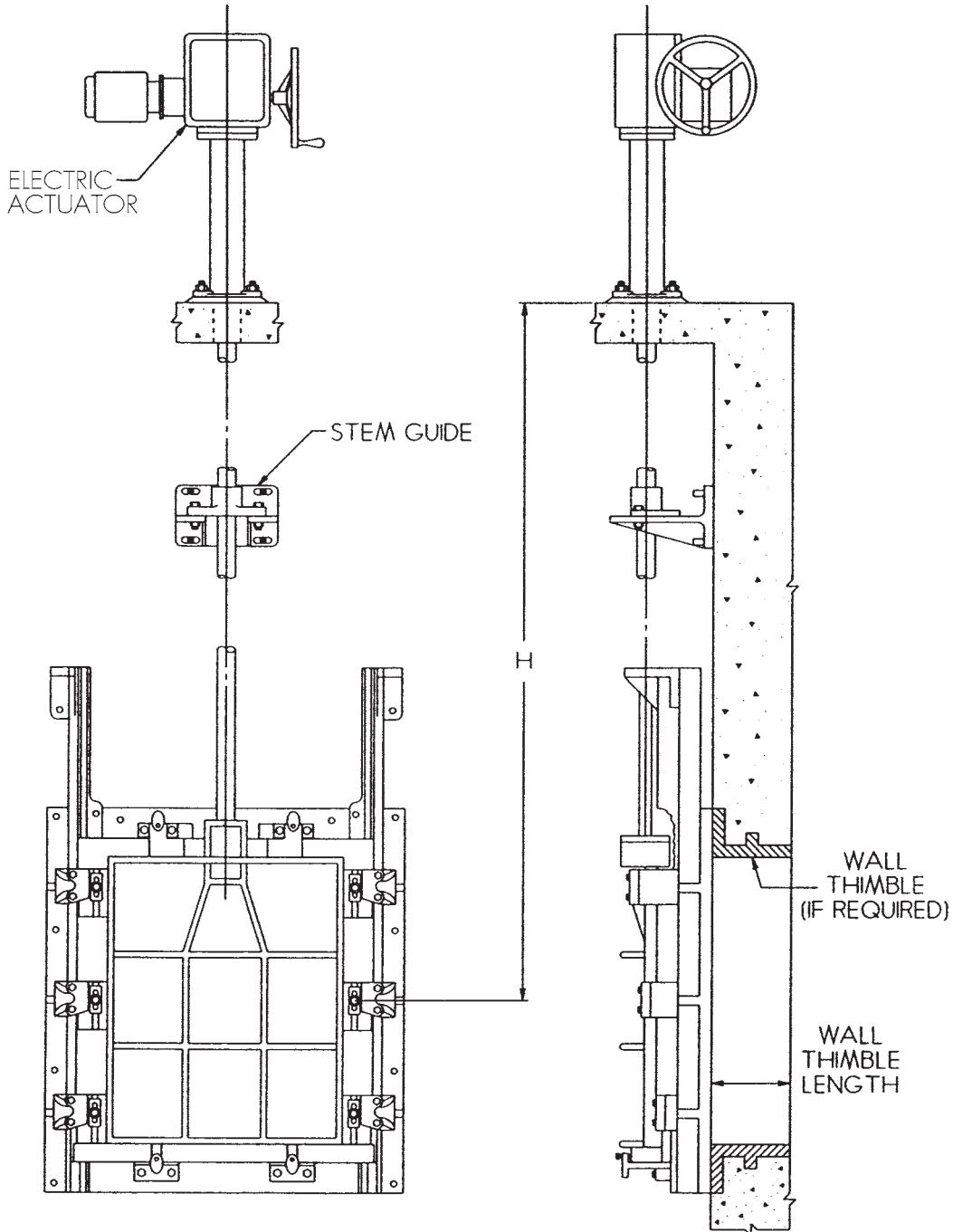

Figure 1-11
Electric Actuator – Heavy-Duty Cast Iron Slide Gate (Series HG-560)

Select Options

- | | | | | |
|--|--|--|---|---|
| <input type="checkbox"/> Rising Stems | <input type="checkbox"/> Standard Bottom | <input type="checkbox"/> Top Wedges | <input type="checkbox"/> Wall Thimble Mount | |
| <input type="checkbox"/> Non-Rising Stem | <input type="checkbox"/> Flush Bottom | <input type="checkbox"/> Bottom Wedges | <input type="checkbox"/> Anchor Bolt Mount | |
| Wall Thimble Length (in inches) _____ | | | | |
| Wall Thimble Type: | <input type="checkbox"/> F | <input type="checkbox"/> E | <input type="checkbox"/> Mechanical Joint | <input type="checkbox"/> Lift Mounted on Concrete |
| Wall Thimble Opening: | <input type="checkbox"/> Round | <input type="checkbox"/> Rectangular | <input type="checkbox"/> Lift Mounted on Wall Bracket | |

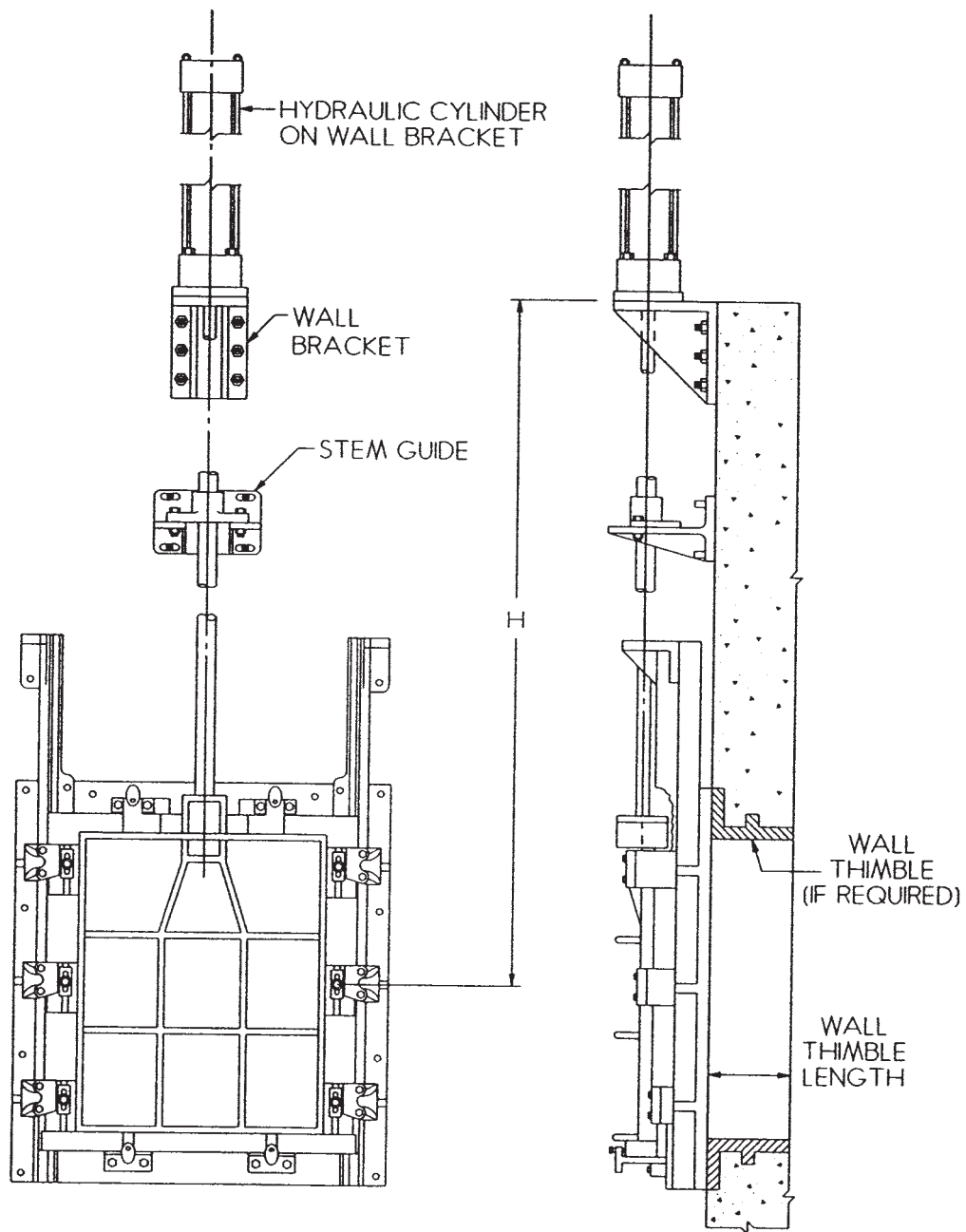

Figure 1-12
Hydraulic Cylinder Mounted on a Wall Bracket – Heavy-Duty Cast Iron Slide Gate (Series HG-560)

Select Options

- | | | | | |
|--|--|--|---|---|
| <input type="checkbox"/> Rising Stems | <input type="checkbox"/> Standard Bottom | <input type="checkbox"/> Top Wedges | <input type="checkbox"/> Wall Thimble Mount | |
| <input type="checkbox"/> Non-Rising Stem | <input type="checkbox"/> Flush Bottom | <input type="checkbox"/> Bottom Wedges | <input type="checkbox"/> Anchor Bolt Mount | |
| Wall Thimble Length (in inches) _____ | | | | |
| Wall Thimble Type: | <input type="checkbox"/> F | <input type="checkbox"/> E | <input type="checkbox"/> Mechanical Joint | <input type="checkbox"/> Lift Mounted on Concrete |
| Wall Thimble Opening: | <input type="checkbox"/> Round | <input type="checkbox"/> Rectangular | <input type="checkbox"/> Lift Mounted on Wall Bracket | |

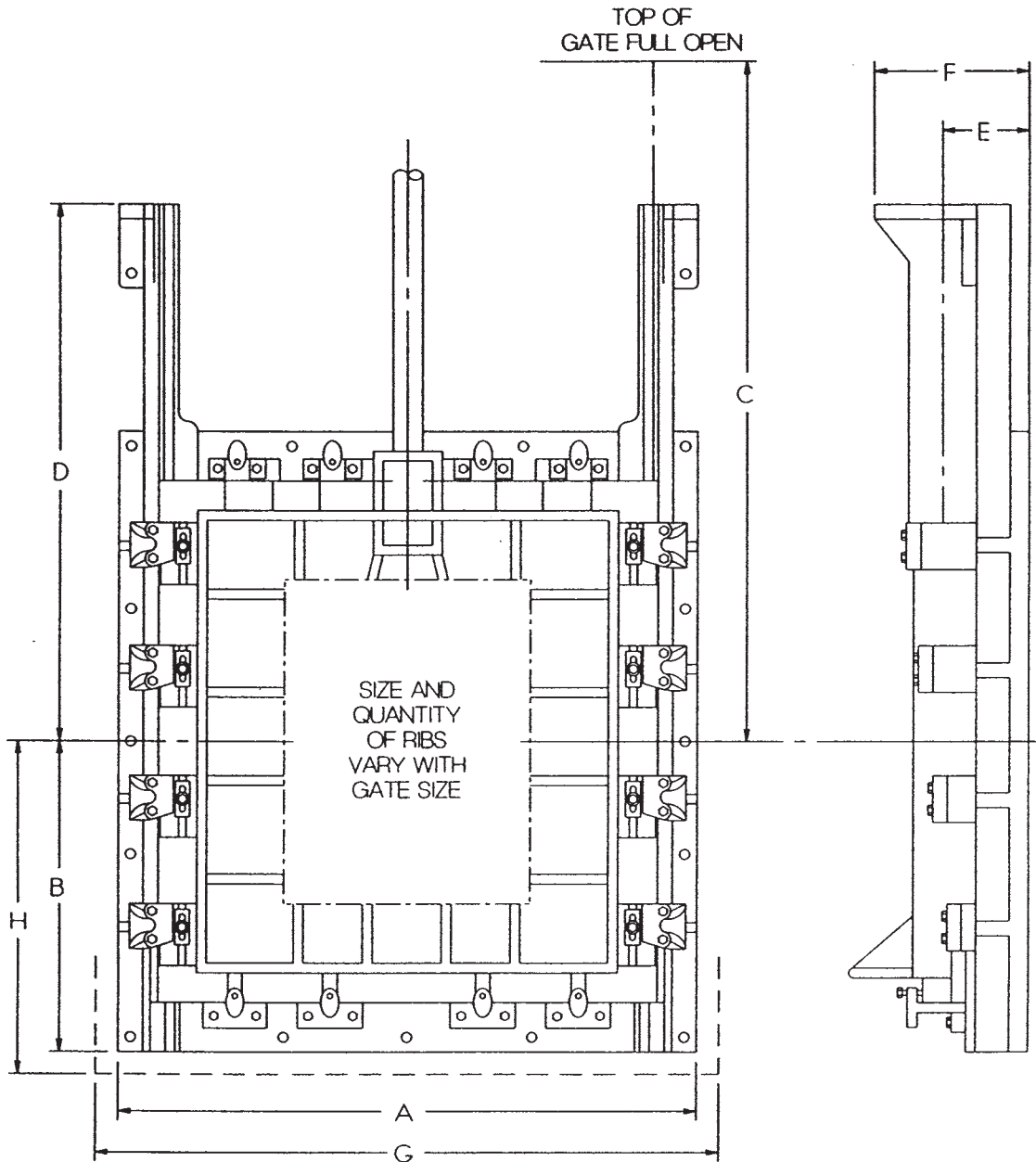

Figure 1-13
Square Opening, 55 Ft Seating Head; 20 Ft Unseating Head – Heavy-Duty Cast Iron Slide Gate (Series HG-560)

This is a design class head rating. Many gate sizes have a higher actual head rating. Please contact Hydro Gate's Engineering Department for maximum head ratings.
 NOTE: G and H are installation clearance dimensions.

Square Opening – Heavy-Duty Cast Iron Slide Gate (Series HG-560)

Gate Size	Flange Back Dimensions							
	Width (A)	Centerline to Bottom of Frame Flange (B)	Centerline to Slide Full Opening Position (C)	Centerline to Top of Frame (D)	Back Mounting Flange to Centerline of Stem (E)	Overall Thickness of Gate (F)	Installation Clearance (G)	Installation Clearance (H)
6 x 6	14.00	7.00	14.37	8.87	5.75	7.25	18.00	9.00
8 x 8	16.00	8.00	16.37	10.87	5.75	7.25	20.00	10.00
10 x 10	18.00	9.00	19.37	12.87	5.75	7.25	22.00	11.00
12 x 12	20.00	10.00	22.37	14.12	5.75	7.25	24.00	12.00
14 x 14	22.00	11.00	26.75	16.87	5.75	8.12	26.00	19.00
15 x 15	23.00	11.50	26.87	17.87	5.75	7.25	27.00	13.50
16 x 16	24.00	12.00	28.37	18.87	5.75	7.25	28.00	14.00
18 x 18	26.00	13.00	31.37	20.87	5.75	7.75	30.00	15.00
20 x 20	28.00	14.00	34.37	22.87	5.75	7.25	32.00	16.00
21 x 21	29.00	14.50	35.87	23.87	6.00	7.50	33.00	16.50
24 x 24	32.00	16.00	41.62	26.87	5.75	8.12	36.00	18.00
30 x 30	38.00	19.00	52.37	32.87	6.37	8.87	42.00	21.00
36 x 36	47.00	23.50	61.37	41.12	7.37	10.87	51.00	25.50
39 x 39	50.50	25.25	66.25	44.25	7.50	11.50	50.50	27.50
42 x 42	53.00	26.50	70.37	47.12	7.50	12.00	57.00	28.50
48 x 48	59.00	29.50	79.37	53.12	7.50	13.50	63.00	31.50
54 x 54	65.00	32.50	91.37	59.12	8.62	16.00	69.00	34.50
60 x 60	73.00	36.50	101.50	65.50	10.00	17.37	77.00	38.50
63 x 63	76.00	38.00	99.62	68.00	10.00	17.37	80.00	40.00
66 x 66	79.00	39.50	106.50	71.00	10.25	18.62	83.00	41.50
72 x 72	85.00	42.50	115.50	77.00	10.25	19.12	89.00	44.00
78 x 78	91.00	45.50	124.50	83.00	10.25	20.12	95.00	47.50
84 x 84	97.00	48.50	133.50	89.00	10.25	21.62	101.00	50.50
90 x 90	103.00	51.50	142.87	95.00	10.25	24.12	107.00	53.50
96 x 96	109.00	54.50	151.87	101.00	10.50	22.87	113.00	56.50
108 x 108	122.50	61.25	169.87	113.00	12.50	23.37	126.50	63.25
120 x 120	134.50	67.25	187.87	125.00	12.62	23.37	138.50	69.25
144 x 144	158.50	79.25	221.25	84.50	13.00	25.00	162.50	81.25

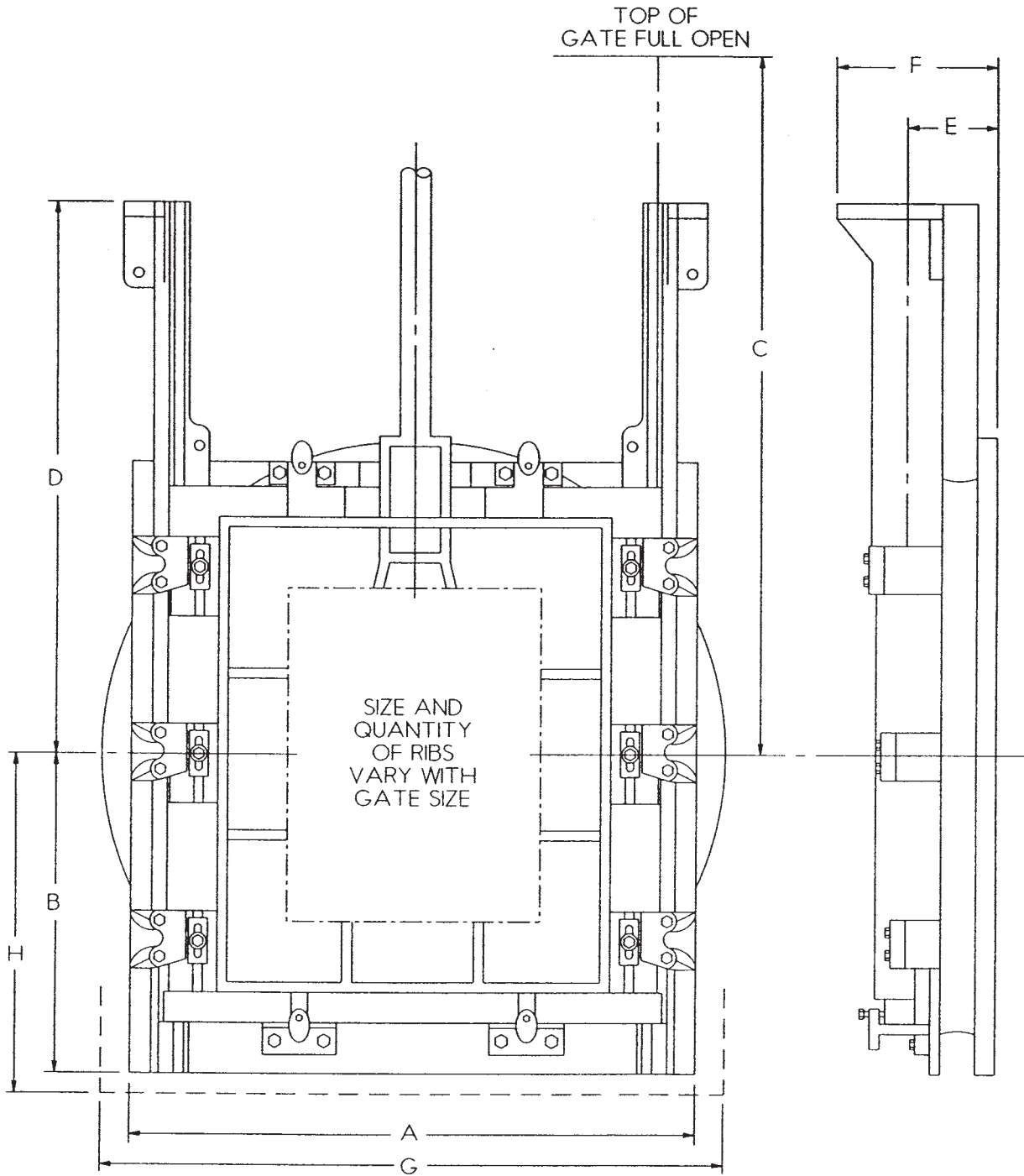

Figure 1-14
Round Opening, 55 Ft. Seating Head; 20 Ft. Unseating Head – Heavy-Duty Cast Iron Slide Gate (Series HG-560)

This is a design class head rating. Many gate sizes have a higher actual head rating. Please contact Hydro Gate's Engineering Department for maximum head ratings.
 NOTE: G and H are installation clearance dimensions.

Round Opening – Heavy-Duty Cast Iron Slide Gate (Series HG-560)

Gate Diameter (In.)	Width (A)	Centerline to Bottom of Frame Flange (B)	Flange Diameter (In.)	Centerline to Slide Full Opening Position (C)	Centerline to Top of Frame (D)	Back of Mounting Flange to Centerline of Stem (E)	Overall Thickness of Gate (F)	Installation Clearance (G)	Installation Clearance (H)
6	12.75	6.50	11.00	13.75	8.87	6.87	8.37	24.00	14.00
8	14.75	7.50	13.50	16.37	10.87	6.37	8.37	26.00	15.00
10	16.75	8.50	16.00	19.37	12.87	6.37	6.87	28.00	16.00
12	18.75	9.50	19.00	22.37	14.12	6.87	8.37	30.00	17.00
14	20.75	10.50	21.00	25.37	16.87	8.37	6.87	32.00	18.00
15	21.00	10.75	22.00	28.25	16.50	6.25	8.50	35.00	18.50
16	22.00	11.25	23.50	29.50	17.75	6.00	8.00	36.00	19.00
18	22.75	12.50	25.00	31.37	20.87	6.87	8.87	38.00	20.00
20	26.75	13.50	27.50	34.37	22.87	7.12	8.62	40.00	21.00
21	27.00	13.75	28.50	38.00	23.00	6.75	8.75	41.00	21.50
24	28.75	16.00	32.00	41.62	26.87	7.25	9.75	44.00	23.00
30	34.75	19.00	38.37	52.37	32.87	8.00	10.25	54.00	30.00
36	44.00	23.00	46.00	61.50	40.00	8.25	11.25	60.00	33.00
42	50.00	25.87	53.00	71.75	44.00	10.00	13.50	66.00	36.00
48	56.00	28.00	59.50	81.25	52.00	9.75	14.75	72.00	41.00
54	62.00	32.00	66.25	91.25	57.00	10.00	15.00	78.00	44.00
60	70.00	35.50	73.00	101.25	64.00	10.75	17.37	90.00	47.00
66	76.00	38.50	80.00	108.75	70.00	10.37	17.25	96.00	50.00
72	82.00	42.25	86.50	117.87	77.00	10.75	18.50	102.00	53.00
78	89.00	44.75	93.50	138.37	83.00	11.25	19.00	108.00	57.00
84	94.00	47.75	99.75	138.00	88.00	11.25	19.25	116.00	60.00
90	102.00	51.25	106.50	144.62	95.00	13.00	19.00	122.00	63.00
96	108.00	54.25	112.50	155.75	101.00	14.00	18.00	128.00	66.00

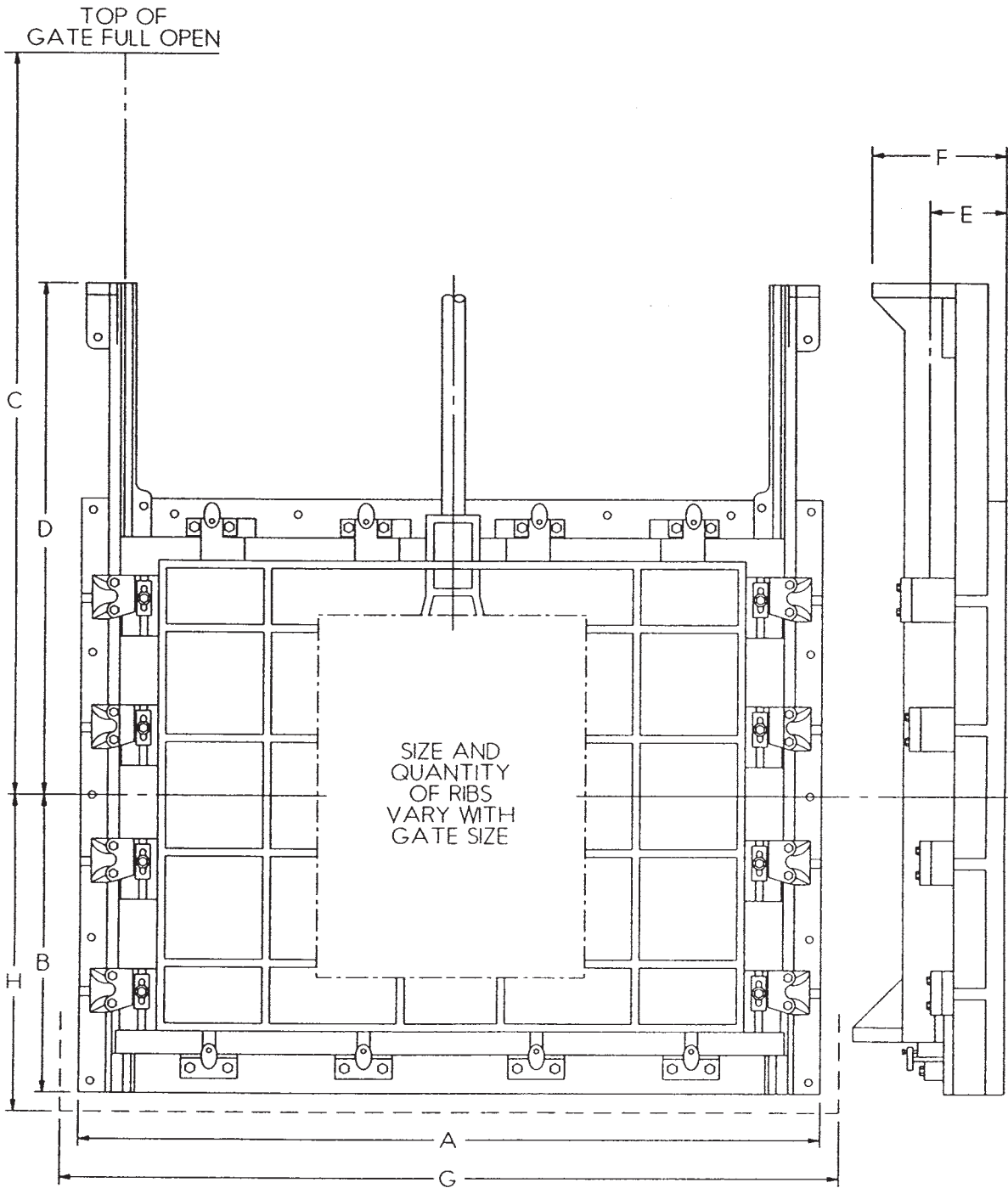

Figure 1-15
Rectangular Opening, 55 Ft. Seating Head; 20 Ft. Unseating Head –
Heavy-Duty Cast Iron Slide Gate (Series HG-560)

This is a design class head rating. Many gate sizes have a higher actual head rating. Please contact Hydro Gate's Engineering Department for maximum head ratings.
 NOTE: G and H are installation clearance dimensions.

Rectangular Opening – Heavy-Duty Cast Iron Slide Gate (Series HG-560)

Gate Size Width x Height	Flange Back Dimensions (In.)							
	Width (A)	Centerline to Bottom of Frame Flange (B)	Centerline to Slide Full Opening Position (C)	Centerline to Top of Frame (D)	Back Mounting Flange to Centerline of Stem (E)	Overall Thickness of Gate (F)	Installation Clearance (G)	Installation Clearance (H)
18 x 24	26.00	16.00	40.37	26.87	5.75	7.25	30.00	18.00
18 x 36	26.00	22.00	61.37	40.87	6.37	8.87	30.00	24.00
24 x 30	32.00	19.00	52.37	32.87	6.37	8.37	36.00	21.00
24 x 36	32.00	22.00	61.37	40.87	6.37	8.37	36.00	24.00
36 x 24	47.00	17.50	43.37	27.87	7.37	10.87	51.00	20.00
36 x 42	47.00	26.50	70.37	47.12	7.50	9.50	51.00	29.00
36 x 96	49.00	54.50	151.50	101.00	8.87	12.25	53.00	57.00
42 x 48	53.00	29.50	79.37	53.12	7.50	12.00	57.00	32.00
48 x 36	59.00	23.50	61.37	41.12	7.50	13.50	63.00	26.00
48 x 60	61.00	36.50	101.25	65.25	8.62	13.50	65.00	39.00
48 x 96	61.00	54.50	151.87	101.00	10.25	16.62	65.00	57.00
60 x 72	73.00	42.50	115.50	78.50	10.25	17.12	77.00	45.00
60 x 84	73.00	48.50	133.50	89.00	10.25	17.62	77.00	51.00
60 x 96	73.00	54.50	151.50	102.50	10.25	18.12	77.00	57.00
66 x 42	79.00	27.50	70.50	46.00	10.25	16.12	83.00	30.00
72 x 48	85.00	30.50	79.50	53.00	10.25	19.50	89.00	33.00
72 x 60	85.00	36.50	97.50	65.50	10.25	19.62	89.00	39.00
72 x 96	85.00	54.50	151.50	101.00	10.25	20.12	89.00	57.00
84 x 96	97.00	54.50	151.87	101.00	10.25	22.12	101.00	57.00
96 x 48	109.00	30.50	79.25	53.00	10.25	22.12	113.00	33.00
96 x 60	109.00	36.50	101.50	65.50	10.25	22.87	113.00	39.00
96 x 72	109.00	42.50	115.50	77.00	10.25	22.12	113.00	45.00
108 x 120	122.50	67.25	187.87	125.00	12.62	23.37	127.00	70.00
120 x 96	134.50	55.25	151.87	101.00	12.62	23.87	139.00	58.00

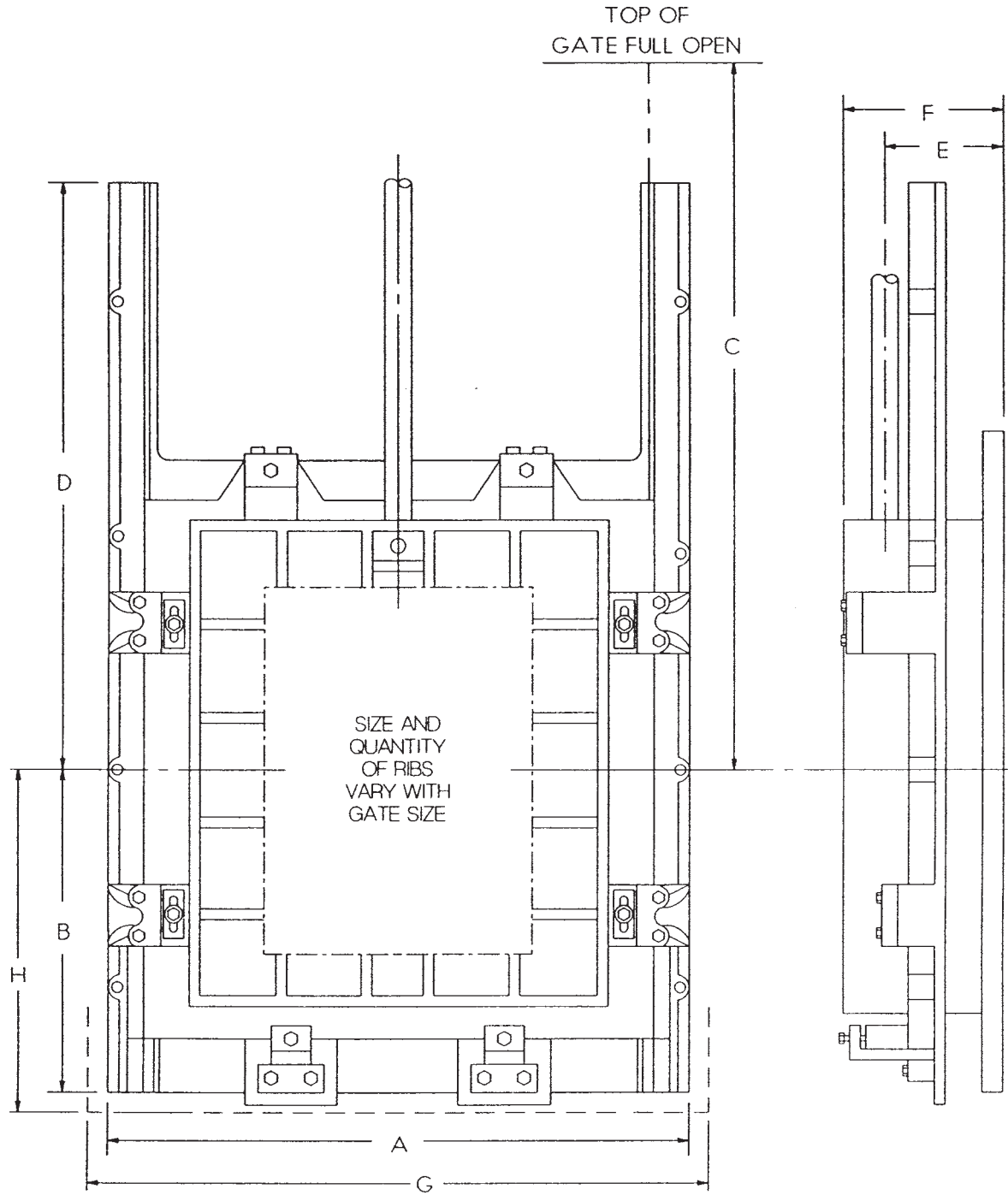

Figure 1-16
Square Opening, 100 Ft. Seating Head; 30 Ft. Unseating Head –
Heavy-Duty Cast Iron Slide Gate (Model 100-30)

This is a design class head rating. Many gate sizes have a higher actual head rating. Please contact Hydro Gate's Engineering Department for maximum head ratings.
 NOTE: G and H are installation clearance dimensions.

Square Opening – Heavy-Duty Cast Iron Slide Gate (Model 100-30)

Gate Size	Flange Back Dimensions							
	Width (A)	Centerline to Bottom of Frame Flange (B)	Centerline to Slide Full Opening Position (C)	Centerline to Top of Frame (D)	Back Mounting Flange to Centerline of Stem (E)	Overall Thickness of Gate (F)	Installation Clearance (G)	Installation Clearance (H)
8 x 8	14.00	7.25	17.87	10.00	6.00	7.50	26.00	15.00
10 x 10	16.00	8.25	20.87	12.00	6.00	8.00	28.00	16.00
12 x 12	18.00	9.25	24.00	13.50	6.00	8.25	30.00	17.00
14 x 14	20.00	10.25	27.75	15.50	6.00	7.50	32.00	18.00
15 x 15	21.00	10.75	28.50	16.50	6.25	8.50	35.00	18.50
16 x 16	22.00	11.25	29.50	17.50	6.25	8.25	36.00	19.00
18 x 18	24.00	13.00	32.75	20.00	7.00	9.25	38.00	20.00
20 x 20	26.00	14.00	36.00	22.00	7.00	9.50	40.00	21.00
24 x 24	30.50	15.75	41.25	26.00	7.25	9.75	44.00	23.00
30 x 30	38.00	19.00	52.25	32.00	8.50	11.00	54.00	30.00
36 x 36	44.00	23.00	59.75	40.00	9.75	12.25	60.00	33.00
42 x 42	50.00	26.00	72.25	44.00	10.00	14.25	66.00	36.00
48 x 48	56.00	28.00	77.12	52.00	10.00	15.50	72.00	41.00
54 x 54	63.00	32.00	91.25	57.00	9.50	14.75	78.00	44.00
60 x 60	70.00	35.50	101.25	64.00	11.00	17.25	90.00	47.00
72 x 72	82.00	42.50	115.75	77.00	11.00	20.00	102.00	53.00
78 x 78	88.00	44.75	125.00	83.00	11.00	19.00	108.00	57.00
84 x 84	94.00	47.75	135.25	88.00	11.00	22.00	116.00	60.00
90 x 90	102.00	51.25	143.87	95.00	14.00	23.00	122.00	63.00
96 x 96	108.00	54.25	153.87	101.00	14.00	23.00	128.00	66.00
108 x 108	119.00	60.25	170.37	113.00	13.25	25.25	140.00	72.00
120 x 120	132.00	66.00	188.75	125.00	14.25	25.00	152.00	78.00

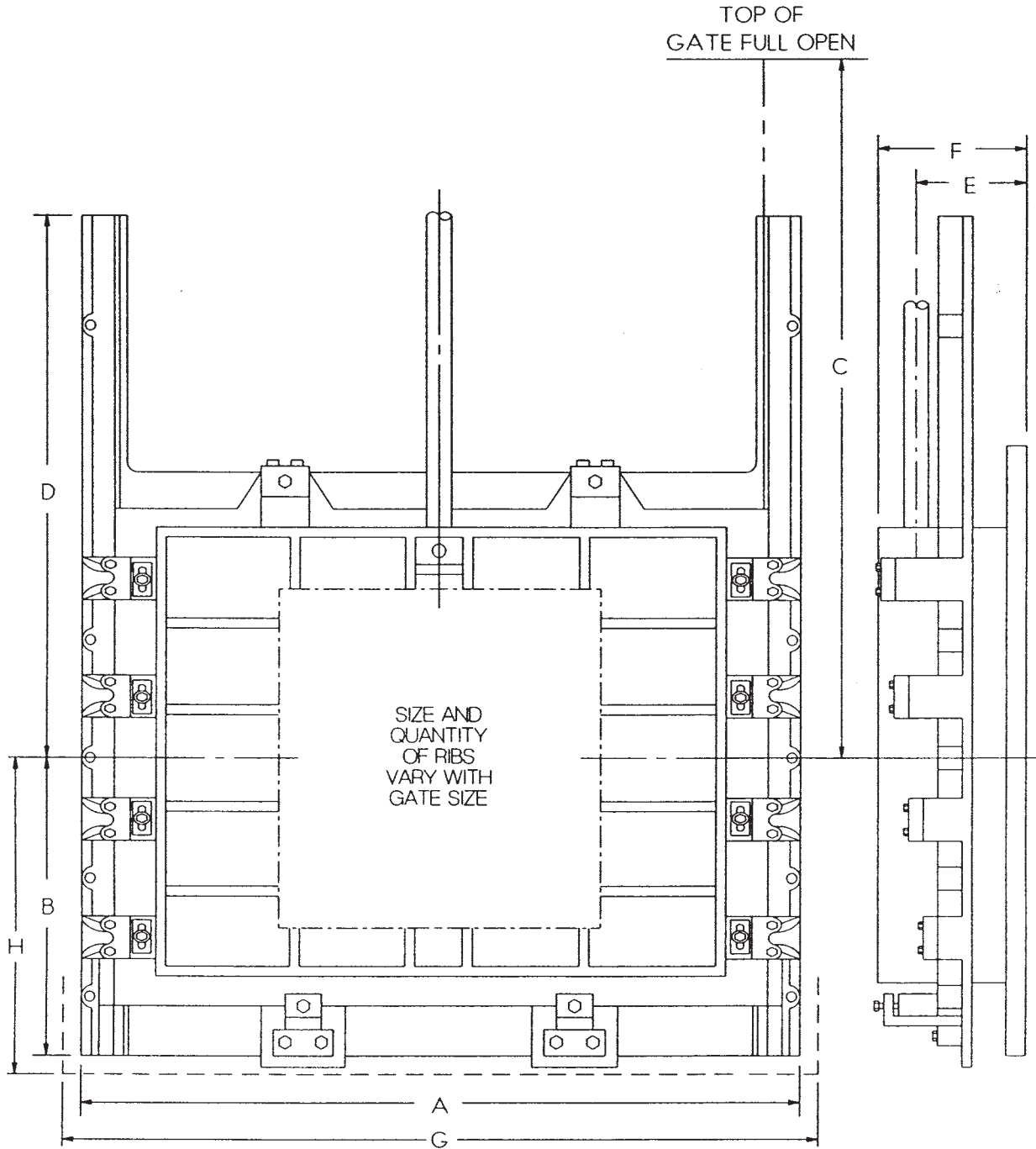

Figure 1-17
Rectangular Opening, 100 Ft. Seating Head; 30 Ft Unseating Head –
Heavy-Duty Cast Iron Slide Gate (Model 100-30)

This is a design class head rating. Many gate sizes have a higher actual head rating. Please contact Hydro Gate's Engineering Department for maximum head ratings.
 NOTE: G and H are installation clearance dimensions.

Rectangular Opening – Heavy-Duty Cast Iron Slide Gate (Model 100-30)

Gate Size Width x Height	Flange Back Dimensions (In.)							
	Width (A)	Centerline to Bottom of Frame Flange (B)	Centerline to Slide Full Opening Position (C)	Centerline to Top of Frame (D)	Back Mounting Flange to Centerline of Stem (E)	Overall Thickness of Gate (F)	Installation Clearance (G)	Installation Clearance (H)
18 x 30	26.00	19.00	51.25	32.00	7.87	11.37	38.00	30.00
24 x 12	30.00	10.00	23.37	13.50	6.50	8.00	42.00	17.00
24 x 18	30.50	13.00	32.62	32.19	6.75	9.00	42.00	20.00
24 x 30	32.00	19.00	52.12	53.25	7.75	11.25	44.00	26.00
24 x 42	32.00	25.00	70.00	46.00	8.25	11.25	44.00	38.00
24 x 48	32.00	28.00	79.12	52.00	8.00	10.25	44.00	41.00
30 x 24	36.50	16.00	42.00	26.00	7.75	9.50	52.00	27.00
30 x 36	38.00	22.00	61.12	64.50	8.00	10.25	54.00	33.00
30 x 48	38.00	28.00	79.50	52.00	9.25	12.25	54.00	41.00
36 x 18	42.50	13.00	35.00	36.00	7.25	10.25	58.00	24.00
36 x 30	44.00	19.00	52.50	54.25	8.75	10.50	60.00	33.00
36 x 48	44.00	28.00	79.50	82.75	9.00	12.25	60.00	41.00
36 x 60	46.00	35.25	100.12	101.37	9.00	12.25	62.00	47.00
36 x 72	46.00	41.00	115.50	77.00	10.00	14.00	62.00	53.00
36 x 84	46.00	47.50	136.12	89.00	10.25	14.50	63.00	57.00
36 x 96	47.00	54.00	153.00	101.00	10.50	15.00	63.00	64.00
42 x 30	50.00	19.00	52.50	55.25	9.00	12.00	66.00	30.00
42 x 36	50.00	22.00	63.00	64.50	8.00	10.25	66.00	33.00
42 x 60	52.00	35.50	99.75	64.00	10.00	13.75	68.00	47.00
48 x 24	56.00	16.00	44.25	46.50	8.75	12.00	76.00	29.00
48 x 30	56.00	19.00	53.87	56.12	8.75	10.75	72.00	29.00
48 x 36	56.00	22.87	63.75	64.25	9.00	13.50	72.00	35.00
48 x 54	57.00	32.75	90.00	93.25	9.56	14.00	74.00	44.00
48 x 72	58.00	41.50	118.25	77.00	10.25	14.50	76.00	53.00
48 x 84	58.00	47.50	136.12	88.00	10.75	14.12	76.00	60.00
54 x 36	62.00	23.00	64.00	65.00	9.50	14.25	78.00	35.00
54 x 72	64.00	41.75	117.50	121.00	10.50	15.00	80.00	53.00
60 x 30	70.00	20.50	54.25	57.25	10.50	16.00	90.00	32.00
60 x 36	68.00	22.50	64.75	64.50	9.25	15.50	84.00	32.00
60 x 48	70.00	29.50	81.87	85.25	10.50	17.00	88.00	41.00

Rectangular Opening – Heavy-Duty Cast Iron Slide Gate (Model 100-30) – continued

Gate Size Width x Height	Flange Back Dimensions (In.)							
	Width (A)	Centerline to Bottom of Frame Flange (B)	Centerline to Slide Full Opening Position (C)	Centerline to Top of Frame (D)	Back Mounting Flange to Centerline of Stem (E)	Overall Thickness of Gate (F)	Installation Clearance (G)	Installation Clearance (H)
60 x 72	70.00	41.50	118.62	77.00	10.50	16.00	90.00	53.00
60 x 84	70.00	47.75	137.12	89.00	11.87	16.75	90.00	59.00
60 x 120	72.00	66.25	192.00	125.00	13.00	19.50	92.00	80.00
72 x 48	82.00	29.50	82.25	52.00	10.50	17.00	102.00	43.50
72 x 84	83.00	47.50	137.12	88.00	11.25	18.50	104.00	60.00
84 x 60	94.00	35.50	101.32	64.00	11.00	19.75	114.00	48.00
84 x 72	94.00	41.50	119.75	77.00	11.00	20.00	114.00	54.00
96 x 48	104.75	29.25	79.75	52.00	9.75	15.25	126.00	42.00
96 x 60	106.00	35.75	98.50	64.00	10.25	15.50	126.00	48.00
96 x 72	106.00	41.75	118.75	77.00	10.50	19.75	126.00	54.00
96 x 84	107.00	47.75	134.12	89.00	10.75	19.75	126.00	60.00
96 x 120	108.00	66.00	186.37	125.00	13.00	17.25	128.00	78.00
108 x 72	120.00	42.75	120.25	77.00	13.25	22.00	138.00	54.00
108 x 96	120.00	54.25	151.50	101.00	13.37	19.87	140.00	66.00
120 x 72	132.00	42.25	120.50	77.00	13.25	24.00	150.00	54.00
120 x 84	131.00	48.00	138.75	88.00	11.75	23.75	152.00	60.00
144 x 96	156.00	54.00	153.75	101.00	14.25	25.00	176.00	66.00

Specifications For Heavy-Duty Cast Iron Slide Gates

General

The contractor shall furnish and install the following cast iron slide gate assemblies as listed on the "Gate Schedule" and detailed on the manufacturer's drawings. The cast iron slide gate assemblies shall include the gate, frame, wall thimble (if required), stem, stem guides, and lift. Cast iron slide gates and installation shall meet the requirements of AWWA C560 except as modified herein. The gate shall be manufactured by Hydro Gate or approved equal.

Materials of Construction

Materials used in construction of gates shall be of the type best suited for the application and shall conform to the following ASTM specifications.

MATERIAL COMBINATION NUMBER 1:

Regular service, normal water, and wastewater.

Frame, Slide, Wall Thimble, Pedestal, Gear Housing, Wall Brackets, and Stem Guide Brackets

Cast iron, ASTM A126, Class B

Wedges and Wedge Blocks

Bronze, ASTM B584, Alloy C862

Lift Nut and Stem Block

Bronze, ASTM B584, Alloy C865

Seating Faces

Silicon Bronze, ASTM B98, Alloy C651

Stems and Stem Couplings

Stainless steel, ASTM A276, Type 304

Fasteners

Stainless steel, ASTM F593/F594, Alloy Group 2

Flush-Bottom Seal

Flush-Bottom Retainer

Stainless Steel, ASTM A276, Type 304

MATERIAL COMBINATION NUMBER 2:

Corrosive environment requiring harder, wear-resistant seating faces and resistance to dezincification.

Frame, Slide, Wall Thimble, Pedestal, Gear Housing, Wall Brackets, and Stem Guide Brackets

Cast iron, ASTM A126, Class B

Wedges and Wedge Blocks

Stainless steel, ASTM A743, CF8M and ASTM A747, Condition SA

Lift Nut

Bronze, ASTM B584, Alloy C86500

Stem Block

Stainless steel, ASTM A743, CF8M

Seating Faces

Stainless steel, ASTM A276, Type 316

Stems and Stem Couplings

Stainless steel, ASTM A276, Type 304

Fasteners

Stainless steel, ASTM F593/F594, Alloy Group 1

Flush-Bottom Seal

Flush-Bottom Retainer

Stainless steel, ASTM A276, Type 304

MATERIAL COMBINATION NUMBER 3:

Normal service except resistance to dezincification of bronze (less than 6% zinc content). Low unseating heads (<20 ft).

Frame, Slide, Wall Thimble, Pedestal, Gear Housing, Wall Brackets, and Stem Guide Brackets

Cast Iron, ASTM A126, Class B

Side Wedges, Wedge Blocks and Stem Block

Silicon bronze, ASTM B584, Alloy C873 or C876

Top and bottom wedges and wedge blocks

Stainless steel, ASTM A743 CF8M and ASTM A747 condition SA

Lift Nut

Bronze, ASTM B584, Alloy C86500

Seating Faces

Silicon bronze, ASTM B98, Alloy C651

Stems and Stem Couplings

Stainless steel, ASTM A276, Type 304

Fasteners

Stainless steel, ASTM F593/F594, Alloy Group 1

Flush-Bottom Seal

Flush-Bottom Retainer

Stainless steel, ASTM A276, Type 304

MATERIAL COMBINATION NUMBER 4:

Highly corrosive applications, seawater.

Frame, Slide, Wall Thimble, Pedestal, Gear Housing, Wall Brackets, and Stem Guide Brackets

Ni-Resist cast iron, ASTM A436, Type 2 or 2b

Wedge and Wedge Blocks

Stainless steel ASTM A743 CF8M and ASTM A747 condition SA

Lift Nut

Bronze, ASTM B584, Alloy C86500

Stem Block

Stainless steel, ASTM A743, CF8M

Seating Faces

Stainless steel ASTM A276, Type 316

Stems and Stem Couplings

Stainless steel ASTM A276 Type 316

Fasteners

Stainless Steel, ASTM F593/F594, Alloy Group 2 (316)

Flush-Bottom Seal

Flush-Bottom Retainer

Stainless steel, ASTM A276, Type 316

Specifications for Heavy Duty Cast Iron Slide Gates

Slide

The gate slide shall be cast iron and shall be of one-piece construction. The slide shall be square or rectangular in shape with integrally cast vertical and horizontal reinforcing ribs. A heavy reinforcing rib along each side shall be provided to ensure rigidity between side wedges. The slide shall be designed to operate under maximum specified unbalanced head with the minimum safety factor of five. Guide tongues along each side of the slide shall be machined all over. A nut pocket shall be cast on the vertical centerline of the gate and shall be provided with a threaded block for attaching the stem to the slide. Pads for side wedges and top and bottom wedges, when required, shall be integrally cast on the slide and machined to receive the adjustable wedges.

Frame and Guides

The gate frame and guides shall be cast iron and shall be a one-piece integral casting. Guide grooves shall be machined on all contact faces. Overall clearances with slide tongue shall be not more than 1/8 in. Faces for mounting of wedging devices shall be fully machined. Guide grooves shall be of such length as to support at least one-half of the slide when it is in the full open position. Frames shall be self-contained (S/C) or not self-contained (NS/C) as listed in the "Gate Schedule." Frames with a spigot-back arrangement are not allowed. Round opening gates shall have a circular flange cast as part of the frame for mounting to a wall or pipe flange. All wall thimble-mounted gates shall have a square or rectangular flanged-back frame. The frame shall be fully machined and drilled to match the wall thimble. Gates mounted on pipe flanges shall be furnished with partial drilling per manufacturer's recommendations.

Yokes

Yokes of self-contained gates shall be cast iron or structural steel. They shall be designed to withstand the thrust of the manual lift when a 40 pound pull is placed on the handwheel or crank with a safety factor of 5 based on the ultimate strength of the material used. The yokes shall be bolted to machined pads on the gate frame.

Seating Faces

Corrosion-resistant seating faces shall be mounted around the perimeter of the slide and frame. They shall be impacted into dovetail slots and held in position without use of screws or other fasteners. After mounting, they shall be machined to a plane with a 63 micro-inch finish or better. When the slide is in the fully closed position and wedged in position against the frame, maximum clearance between seating faces shall not exceed 0.004 in.

Wedges

Each gate shall be provided with a sufficient number of wedges to provide a practical degree of water-tightness. Side wedging devices shall be designed to make full metal-to-metal contact with the overhung portion of the frame-mounted

wedge block. Wedges shall be fully adjustable and keyed to prevent any lateral rotation. Side wedges shall be machined with angled faces and secured with a stud bolt to prevent any slippage during operation of the gate. Gate shall be designed with adjustable top and bottom wedges attached to the frame and slide. The top and bottom wedges shall be mounted in a machined slot and bolted to the slide to prevent lateral rotation. All contact faces of wedges and wedge blocks shall be precision-finished with 63 micro-inch finish or better.

Flush-Bottom Seal

Flush-bottom gates shall be provided with a frame-mounted flush-bottom seal. The solid bulb resilient rubber seal shall be firmly held in place using stainless steel retainers and corrosion-resistant fasteners. The full length of the bottom edge of the slide shall be machined for making uniform contact with the seal when it is mounted on the frame. The differential pressure on the rubber seal shall be variable by adjustment of wedges on the gate.

Wall Thimble

Wall thimble shall be a heavy, one-piece iron casting of an E, F or mechanical joint type configuration. A center ring or water stop shall be cast around the periphery of the thimble. The front face of the thimble shall be machined and holes drilled and tapped for attaching the gate with corrosion-resistant metal studs. The vertical centerline shall be clearly marked at top and bottom to permit alignment of the front face in the vertical plane. Wall thimbles shall be internally braced during concrete placement to prevent warping. Square thimbles shall be provided with holes in the invert to allow satisfactory concrete placement beneath the thimble. Holes shall be on centers of 24 inches or less. A rubber gasket of uniform thickness or a mastic shall be used to form a seal between the front face of the thimble and the back of the gate frame. E-type or mechanical joint wall thimbles shall have the back flange drilled and machined as shown in the plans or specified in the "Gate Schedule."

Stem and Stem Splices

Stems shall be manufactured from stainless steel sized to withstand the axial compressive and tensile forces created during gate operation under the specified unbalanced heads and to transmit in compression at least two times the rated output of the lift with a 40-lb effort on the crank or handwheel, or 1.25 times the stall thrust of the electric actuator. Threading on stems shall be rolled with double-lead threads of the Acme type. Cut threads will not be allowed. The contact surfaces of the threads shall have a maximum 16 micro-inch finish. Stem couplings shall have internal threads for transmitting the full thrust of the stem and shall be held in place on the stem with a key, simultaneously engaging the coupling and both stems.

Stem Guides

Stem guides shall be fully adjustable, heavy duty castings, with 2 piece cast bronze removable collars. The stem guides shall be properly spaced to support the stem as a long column, with maximum spacing not to exceed an 1/r of 200.

Lifts

Manual Lifts – The lifts shall be of the handwheel or enclosed gear type. Gears shall be steel with machine-cut teeth designed for smooth operation. The gearing and lift nut shall be mounted in a cast iron housing which, in turn, shall be supported by a cast iron or structural steel pedestal to place the input shaft approximately 36 in. above the floor. Lubrication fittings shall be provided in the gear housing to permit lubrication of all gears and bearings. A maximum effort of 40 lbs shall be required to operate the gate after it is unseated from its wedging devices. All rising stem gates shall be supplied with a clear plastic stem cover. Geared lifts shall be suitable for manual and portable motor operation. Lift nuts shall be high-strength bronze. Oil bath lubrication shall not be allowed.

Stem Covers – Rising stem gates shall be provided with clear plastic stem covers that will not discolor, crack or become opaque for at least 5 years after installation. The covers shall be capped, vented, and long enough to allow full travel of the gate.

Electric Powered Lifts – Motor actuator shall be a 460-V, 3-phase, 60-Hz motor with precision reduction gearing enclosed in a weatherproof housing. The actuator shall be designed to raise the gate at a rate of approximately 12 in./min. Integral controls shall include a control power transformer, reversing controller, torque and limit switches required for controls and remote indication, space heater to prevent condensation, open-stop-close push-buttons, and gate position indicator. Where applicable, the controls shall also include a local-off-remote selector switch. Motor reduction helical gear and pinion shall be of heat-treated alloy steel. Final reduction worm shall be of alloy steel and worm gear of machined high-tensile-strength bronze. All gearing shall be proportioned for 100% overload condition. Operator shall have a declutch lever and handwheel for manual operation.

Fasteners

All anchor bolts, studs, assembly bolts, cap screws, nuts, and adjusting screws shall be of ample section size to withstand the

force created by operation of the gate under full heads of water specified and shall be stainless steel.

Installation

All parts shall be installed and adjusted by the contractor in a workmanlike manner. The manufacturer shall furnish necessary drawings and detailed installation, operation and maintenance instructions for all components. It shall be the contractor's responsibility to handle, store, and install all parts and adjust switches and controls in accordance with the manufacturer's detailed written recommendations. Stem threads shall be lubricated prior to operation of the gate.

Cleaning and Coating

Cleaning and coating shall be performed at the manufacturer's plant. Rust, mill scale, dirt and grease shall be removed by commercial blast cleaning (SSPC SP-10) method. Paint shall be manufacturer's standard or in accordance with paint specifications in the paint section.

Leakage

After installation and before the gates are put into operation, a leakage test shall be performed on all cast iron slide gates in accordance with AWWA C560. Excess leakage shall be reduced to this maximum by adjusting the gate and its wedges.



Positioning large cast frame for machining

Gate Schedule								
Quantity Required	Size of Opening (In.) (W x H)	Gate Type: Self-Contained or Not Self-Contained	Maximum Operating Head (Ft)		Bottom Type Flush/Std.	Operator Manual/Electric	Material Combination	Remarks
			Seating Design/Operating	Unseating Design/Operating				

Wall Thimble-Mounted Gate Schedule									
Quantity Required	Size of Opening (In.) (W x H)	Gate Type: Self-Contained or Not Self-Contained	Maximum Operating Head (Ft)		Bottom Type Flush/Std.	Operator Manual/Electric	Wall Thimble Type Length	Material Combination	Remarks
			Seating Design/Operating	Unseating Design/Operating					

